

all dimensions in mm

Component list

1	Base element, PA	1
2	Signal conductor, Cu Pure copper	1
3	Pressure nut, PC	1
4	Marking ring, PA	1
5	Indicator, retaining element, PC	1
6	Damping unit, TPE	1
7	Pressure ring, PC	1
8	Counter nut, PA	1
9	Double Stepp washer, PA	1
10	Covering ring, PC	1
Extent of delivery 1 – 10 mounted		
Revision date 10.05.2011		

¹⁾ LOCTITE is a registered trademark of Henkel • WBT und nextgen sind eingetragene Marken der WBT Germany

nextgen™ Pole Terminal WBT- 0708

(Internat. Patents and Design Patents
EP 1 470 620, Pat. pend.102011007940)

Pole terminal for cabinet wall mounting, *plug - / solderversion*

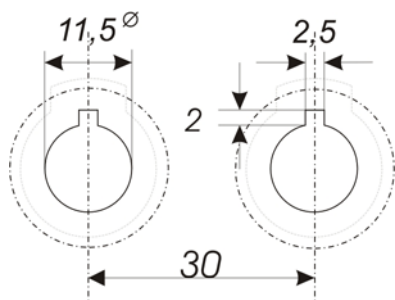

Mounting suggestion or
hint: impact sound interrupter WBT - 0718



IEC, EN und RoHS konform
UL – style: V1

1. Mechanics

- One piece, low tolerance contact element
- Fully insulated construction
- Indication of fastening power (torque control)
- Locking feature for contact pressure
- Vibration damping against sound impact

2. Materials

- Signal conductor (2) pure copper
- Base element (1) PA
- Counter nut (9) PA
- Marking ring (4) and double step washer (9) PA
- Damping ring (6) TPE
- Indicator / retaining (5), pressure ring (7) PC
- Pressure nut (3) and covering ring (10) PC

3. Surfaces

- Signalleiter: gold plated, Ni-free, non ferromagnetic

4. Operating characteristics (reliably observed after more than >10³ connection / disconnections)

- Permanent current $I_D \geq 30$ A
- Peak current $I_S \geq 200$ A
- Transition resistance $R_{ij} < 0,1$ mOhm (measured with spade connection)
- Contact resistance $R_{DAg} < 0,14$ mOhm (measured with spade connection)
- Insulation resistance $R_{iso} > 10^{10}$ Ohm (500V)

5. Connection options

- solder (optimal for cable up to 4 mm² / 11 AWG)
- plug (for 6.3 mm flat push-on shoe)

6. Mounting

- chassis drill hole $\varnothing 11.5^{+0.2}$ mm with slot 2.5x2 mm for twist prevention (see left → drilling scheme)
- for wall thickness from 0,9 to 10,0 mm, with Puzzle plate WBT-9410 from 0,9 to 8,0 mm
- recommended distance between two terminal centres: 30 mm
- recommended tightening torque for the counter nut(8): 1.8 Nm
- recommended fluid nut lock for the counter nut (8): LOCTITE 480 ¹⁾

7. Mounting suggestion

- impact sound interrupter WBT – 0718,
- cabinet wiring with nextgen™ female blade connector WBT – 0650 / -0655, 30 A with contact retaining and vibration damping